

Outer shell , inner shell	: Brass (UNS C38500)	Chrome plated (FS-QQ-C-320B)
Latch sleeve	: Special brass	Nickel plated (FS-QQ-N-290A)
Collet nut	: Brass (UNS C38500)	Chrome plated (FS-QQ-C-320B)
Insulator	: PTFE	-
Male contact	: Brass (UNS C38500)	Gold plated (ISO 27874)
Insulating sleeve	: PA6.6	-
Threaded ring , square piece	: Brass (UNS C38500)	Chrome plated (FS-QQ-C-320B)
Other metallic parts	: Brass (UNS C38500)	Nickel plated (FS-QQ-N-290A)

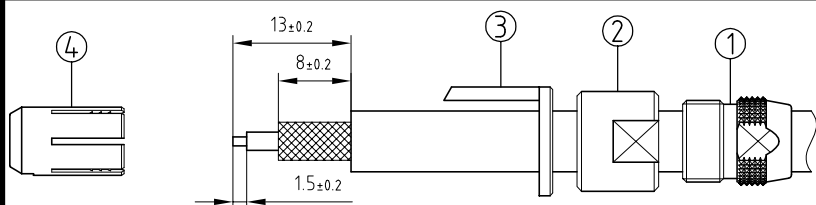

1. Strip the cable according to the given dimensions . Slide it into the collet nut①, the threaded ring②, the square piece③and collet④ .

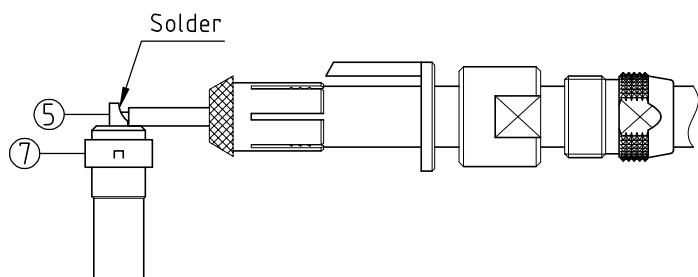

2. In case of a screened cable , fold screen back over the extremity of the collet . Fit the conductor into the contact⑤and solder . Verify that insulator and insulation remain clean .

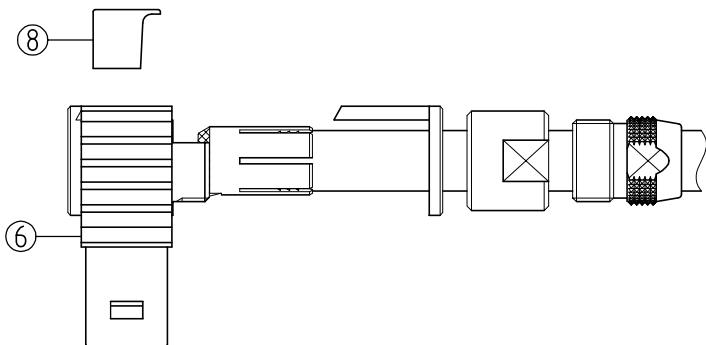

3. Slide the subassembly into the plug outer shell⑥, ensure that the keys inside the shell goes into the appropriate keyway on the insert carrier⑦ and introduce the insulating sleeve⑧into the shell . Slide the collet by ensuring that its keyway goes on the key of the inner shell and cut , if necessary , the excess screen .

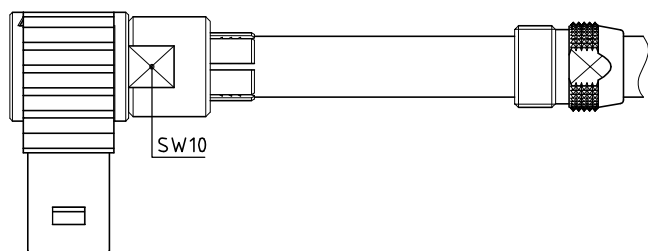

4. Slide the square piece on the thread until it butts and screw the threaded ring with the appropriate tool and tighten to the maximum torque value of 2Nm .

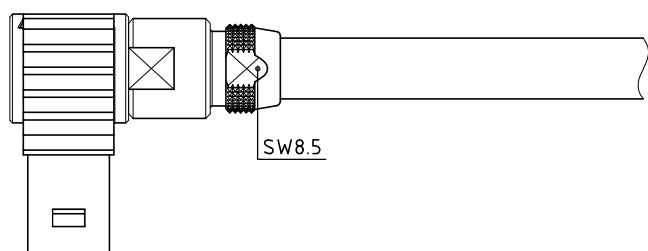

5. Screw the collet nut with appropriate tool and tighten to the maximum torque value of 1,5Nm .

Flat spanners set : DCP.91.001.TN

**Elbow plug (90°) , with cable collet .
Series 1S , coaxial (50Ω)**

Echelle	Dessiné	01.06.2015	OVU / NHA
	Contrôle	01.06.2015	NHA / ATVI
	Modif.	00	01.06.2015/ OVU

ETUDE N°